

# Monitors

## Sentinel 40mm Type 2 Monitor



Fire Engineering  
Pty Limited



### Description

The Sentinel 40mm manual monitor is an stainless steel monitor with friction swivel locks. The monitor can be used with a range of 40mm BSP nozzles including Orion Model A-40 or NP250-40 fog nozzles. The monitor features a balanced design with no net reaction force applied to the monitor from the nozzle and an even weight distribution for easy operation. Swivels are sealed and can be lubricated using the grease nipples.

### SPECIFICATION

Maximum Flow:	500
Horizontal Rotation:	360°
Vertical Movement:	120°
Inlet Connection	40mm BSP M
Outlet Connection	40mm BSP M
Maximum Working Pressure	700 kPa

### Options

Inlet Flange: 40mm Table E flange. Other sizes and flange types are possible.

---

## ORION FIRE ENGINEERING PTY LIMITED

A.B.N. 80 002 538 696

Tel (61) 2 9426 7900 26A LYN PARADE PRESTON NSW 2170 FAX (61) 2 8783 5400  
AUSTRALIA

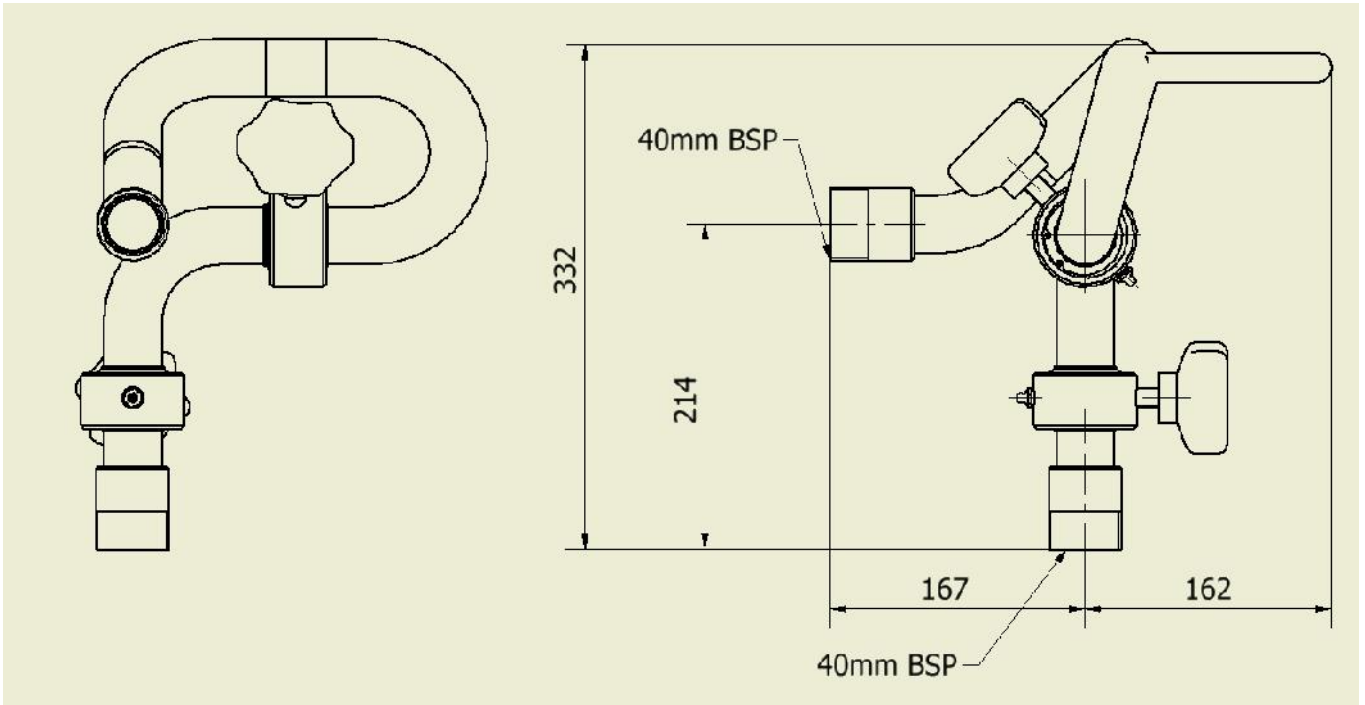

### Friction Loss Curve

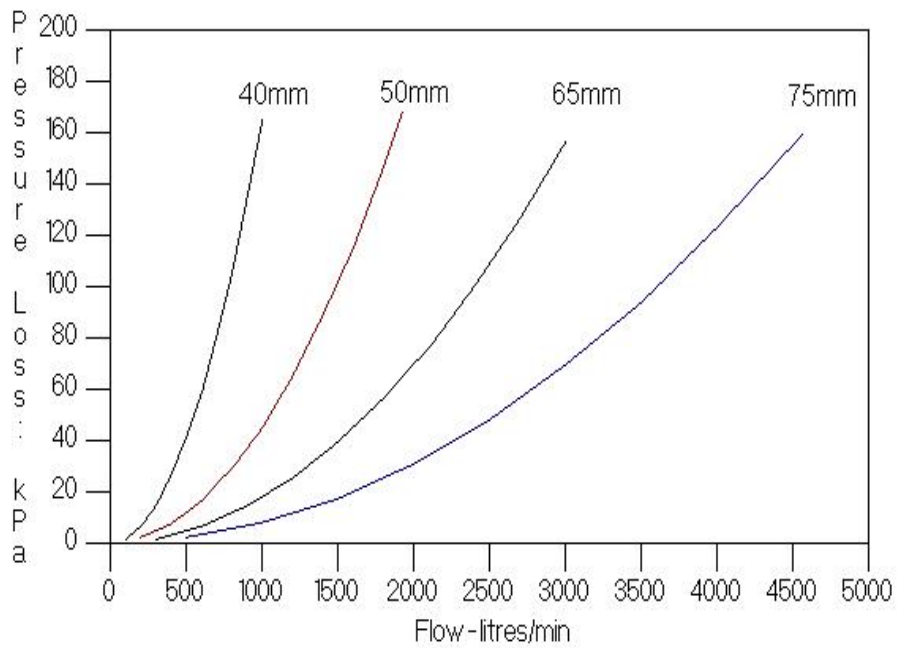

### Materials of Construction

Waterway:	316 Stainless Steel
Swivels:	316 Stainless Steel
Grease Nipples:	316 Stainless Steel
Locking Knob:	Plastic
Elevation Handle:	316 Stainless Steel

---

## ORION FIRE ENGINEERING PTY LIMITED

A.B.N. 80 002 538 696

Tel (61) 2 9426 7900 26A LYN PARADE PRESTON NSW 2170 FAX (61) 2 8783 5400  
AUSTRALIA